



CLEAN INDIA

Mfrs. of Cleaning Automation Products

GREEN INDIA



An ISO 9001 - 2015 Certified Company

WOOD DUST COLLECTOR





WOOD DUST COLLECTOR

CLEANTEK Wood Dust Collector is useful to collect the Sawdust, Chips, wood Shaving and Granular Materials, plastic chips, etc. We have firmly positioned ourselves as one of the flourishing Wood Dust Collection System Manufacturers based in India.

We are a renowned manufacturer and supplier of Wood Dust Collectors that are fabricated as per the international standards. The equipment offered by us, are precision engineered and designed by our engineers to focus on wood industries to collect any dimension and quantity of wooden dusts. We offer them at most reasonable prices.

Centralized Multi point Wood Dust Collector:

In modern wood processing cutting machines and grinding machines are running in very high speed and deliver the lot of dust. These dust materials are deposited inside the precision parts and circuit boards and it affected serious problems.

To avoid this we offer solutions for to extract the complete saw dust from the cutting source. We design and supply different ranges of suction hoods and dust extractors. Sucked saw dust collected in the filter bags and it will be removed manually. Depend upon the application pre-separators. Additional filter bags are suggested. These models available upto 20000 CFM airflow capacity.

MODELS



DCWD50



DCWD100



DCWD200



DCWD300



DCWD500



DCWD700/1000

FEATURES

- Efficient filtration design
- Outstanding dust Extraction force
- Minimum dust emission level
- Continuous operation 24/7
- Efficient cleaning system
- Cost-efficient solution
- Modular built design
- Mobile use in the workshop

APPLICATIONS

- Home Cabinet Manufacturers
- Wood Panel Manufacturers
- Packing Pallet Manufacturers & Home Flooring Manufacturers
- Home Window Manufacturers & Home Door Manufacturers
- Wood Photo Frame Manufacturers
- Office Furniture Manufacturers & Plywood Production industries
- Veneer Shops & Lumber Board Manufacturers
- MDF board Manufacturers
- Architectural Wood Product Manufacturers

TECHNICAL SPECIFICATION

PARAMETERS	DCWD100	DCWD200	DCWD300	DCWD500	DCWD700	DCWD1000	DCWD1500
HP	1	2	3	5	7	10	15
Volts/Hz	415/50	415/50	415/50	415/50	415/50	415/50	415/50
Airflow in m3/Hr	1100	1850	2200	3200	6000	7500	10000
Speed in RPM	2880	2880	2880	2880	2880	2880	2880
Suction inlet size in mm	100	125	150	200	300	350	400
Number of Filter Bag / Filtration level	1 Pair / 30 Micron	2 Pair / 30 Micron	2 Pair / 30 Micron	2 Pair / 30 Micron	4 Pair / 30 Micron	4 Pair / 30 Micron	4 Pair / 30 Micron
Suction inlet mm	∅ 100	∅ 100	2 X ∅ 100	4 X ∅ 100	4 X ∅ 100	4 X ∅ 100	4 X ∅ 100
Type of motor	Flange Mounted	Bed Mounted	Bed Mounted	Bed Mounted	Bed Mounted	Bed Mounted	Bed Mounted
Motor Protection	IP55	IP55	IP55	IP55	IP55	IP55	IP55

DCWD Single Filter Bag

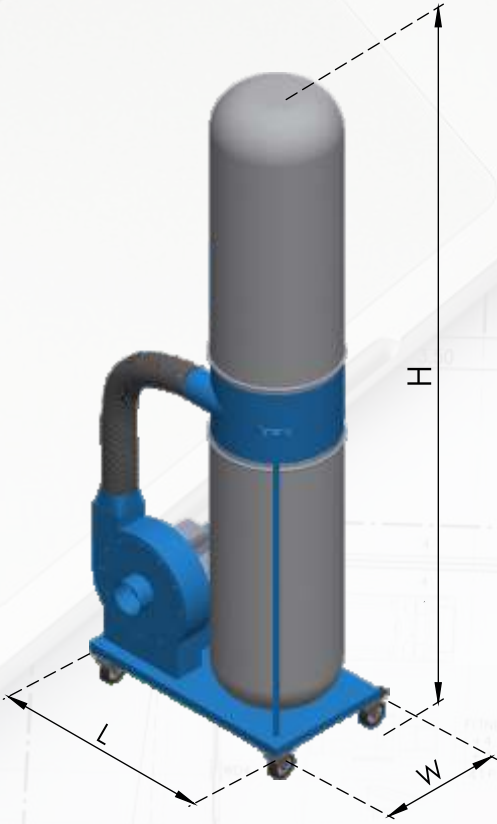

MODEL	L	W	H
DCWD 100	930	515	2560
DCWD 200	930	515	2560

All Dimensions are in mm

DCWD Double Filter Bag

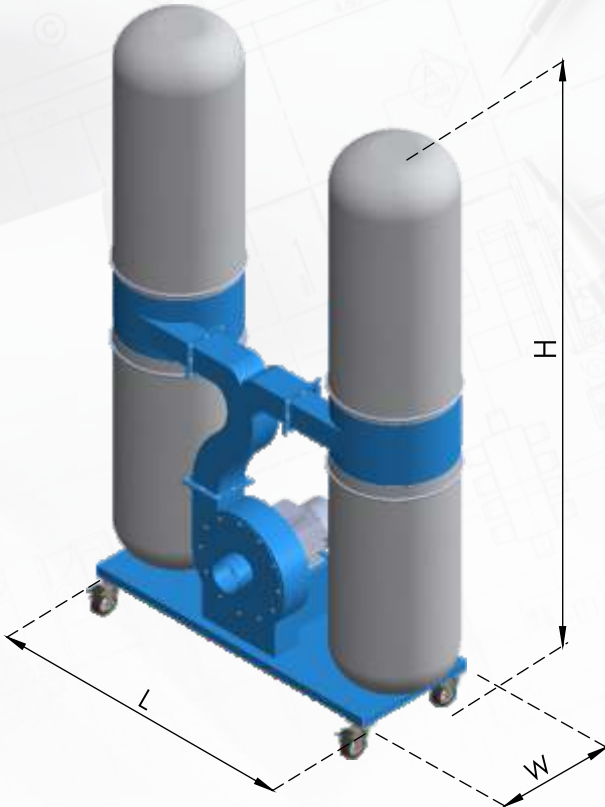

MODEL	L	W	H
DCWD 200	1510	545	2600
DCWD 300	1580	545	2600
DCWD 500	1645	545	2600

All Dimensions are in mm

APPLICATIONS



APPLICATIONS



OUR OTHER PRODUCTS



Air knife



Axial Fan Blower



Centralized Vacuum Cleaner



Wet And Dry Vacuum Cleaner



CNC Oil Mist Collector



Dust collector



Hopper Loaders



Hot air Blower



Oil Sump Cleaner



Paint Booth



Centrifugal Blower



Welding Fume Extractor



Three phase dry Vacuum Cleaner



Industrial Vacuum Cleaner wet & Dry



Trim Suction Unit



Wood Dust Collector



Government of India Ministry of Finance

**CERTIFICATE
OF APPRECIATION**

The Central Board of Indirect Taxes and Customs conveys its appreciation to M/s **CLEANTEK** having GST registration number **33AMCPB0547M1ZD** for their prompt filing of returns and payment of Goods and Services Tax upto the year ending 31st March 2021, thereby substantially contributing to building a strong and resilient nation.

M. Ajit Kumar
Chairman (CBIC)

Sl.No.	DESCRIPTION	CLEANTEK
1	Date Of Registration of Establishment	07 – 09 - 2006
2	Founder & Chief Executive	A. Krishnamoorthy
3	Experience In this Field	25 Years
4	Date Of Registration of Establishment	Own Building Own R & D Own Manufacturing Facility Assembly & Testing Facility New Developments Support Sales & marketing Installation & Service Support Team
5	Number Of Employees	50+
6	Installation	Satisfied clients 10,000 +
7	Head Quarters	Coimbatore
8	Certification	An ISO 9001-2015
9	Quality	Organized & Quality Management System
10	Branches	Chennai , Bengaluru, Coimbatore
11	Membership	CODISSIA, SIEMA, ICCI, BIEOA
12	Registered in Govt	ESI, EPF, NSIC
13	Trade mark	Registered
14	Industry	MSME

THANKS FOR OUR VALUABLE CUSTOMERS

DRESSER-RAND
A Siemens Business



FLOWERVE

MAHLE



Craftsman
OUTSIDER TOOLS

ELGI
Always Better.

MRF



Kanam
KANAM LATES INDUSTRIES PVT LTD



WHEELS INDIA LIMITED

KYB
Our Precision. Your Advantage



BROKES INDIA PRIVATE LIMITED

HANON
SYSTEMS

MITSUBA
MITSUBA SICAL INDIA PRIVATE LIMITED



Rane
Expanding Horizons



Astrotech Steels
Private Limited

DOOWON

L&T Valves

JK Fenner

BOSCH

EVEREST



ROYAL ENFIELD

TEAL

Shobikaa DuraNet



TITAN



JANATICS
Pneumatic



COMSTAR **PLAST**

IDEX

KOHLER

WOOSU INDIA



PREMIER
eXOLICS

BONFIGLIOLI
Power & Control Solutions

Suprajit

More than 6000+
customers all over India & Abroad



CLICK HERE FOR OUR
FACEBOOK PAGE



www.cleantekindia.com



CLICK HERE FOR OUR
DEMO VIDEOS



+91 9500266693

+91 9994352001 | +91 9894214994



0422-2984994



sales@cleantekindia.com | krishna@cleantekindia.com



COIMBATORE

Head Office

479/4, Site No.22 & 23,
Balaji Industrial Estate,
Kondagampalayam Main Road,
Keeranatham, Saravanampatti Po,
Coimbatore - 641 035,
Tamil Nadu, India.



BANGALORE

Branch Office

C-13, 3rd Floor,
Resident No: 251, Malur Ramaiah
Compound, Jaibheema Nagar,
1st Cross, BTM Layout,
1st Stage Old Madiwala,
Bangalore-560 068, India



CHENNAI

Branch Office

4th Main Rd, Moovendar Nagar,
Bharathi Nagar, Tambaram,
Chennai,
Tamil Nadu-600063, India